

## 1/2" CONDUIT MOUNTING DIE CAST ZINC • SPEC GRADE

2100 SERIES

### APPLICATIONS

Use to control parking lot & building perimeter lighting, outdoor sign lights.

### FEATURES

- Heavy-duty die cast zinc, gasketed for maximum weather protection.
- Delay of up to two minutes prevents false switching due to light from vehicles, lightning etc.

### SPECIFICATIONS

**Turn ON / Turn OFF:** Turn-ON is 1 to 5 fc, turn-OFF is 3 to 15 fc, without the slide in position. ON/OFF adjustment is easily done by moving a light level selector - no tools required.

**Cell:** Cadmium sulphide, epoxy coated, 1" diameter.\*

**Contacts:** Remain closed between dusk and dawn. (Note: The unit fails in the ON position)

**Power Consumption:** Averages under one watt.

**Temperature Range:** -40° to +140°F (-40° to +60°C)

**5 YEAR WARRANTY\***

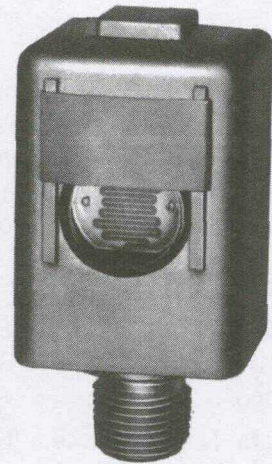

2101 / 2104 / 2107

### ORDERING INFORMATION

MODEL	VOLTAGE		RATING	
	50-60Hz	SWITCH	TUNGSTEN	BALLAST
2101	120	SPST	2000W	1800VA
2104	208-277	SPST	2000W	1800VA
2105* not UL or CSA	120	SPST	3000W	3000VA
2107 <b>NEW</b>	120/277	SPST	2000W	1800VA

\* Model 2105 has a polycarbonate enclosure, 1/2" cell, 1 year warranty.

### DIMENSIONS

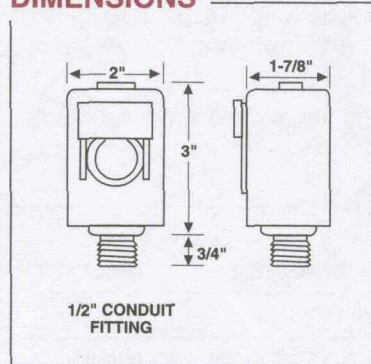

### ACCESSORY

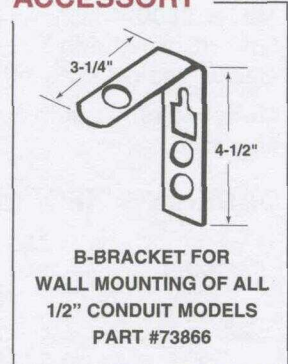

### WIRING DIAGRAMS

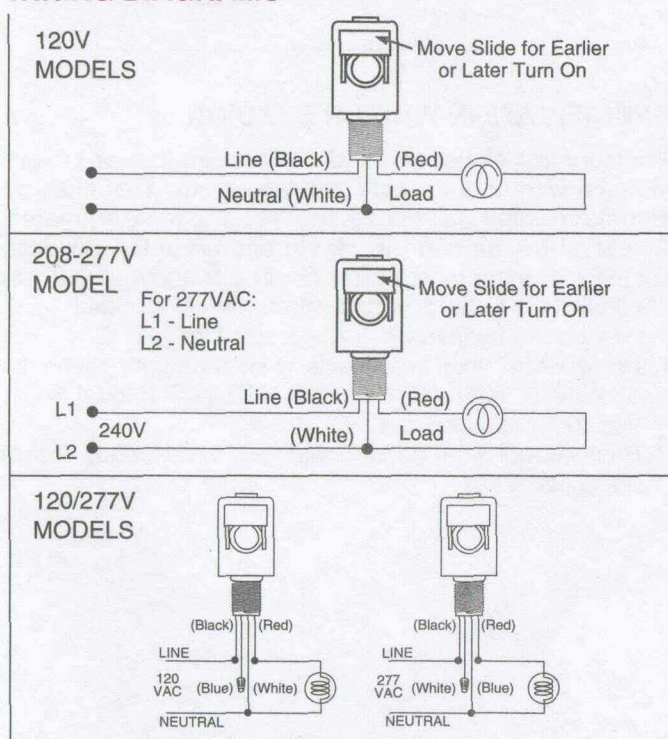

### SPECIFICATION WRITER'S GUIDE

Photocontrol enclosure shall be constructed of die cast zinc, gasketed for weather protection. Cell shall be cadmium sulphide, epoxy coated, one inch diameter. Contacts shall be normally closed and fail in the ON position. Photocontrol must withstand temperatures of -40° to +140° F. Unit to be provided with three color coded, minimum six inch wire leads, #16 AWG, rated for 105° C. Photocontrol shall have a fixed base for mounting through 7/8 inch opening or 1/2 inch K.O. Furnish and install TORK Model 2101, 120 VAC (Model 2104, 208-277 VAC), (Model 2107, 120/277 VAC) or equal.